

**TECHNICAL BULLETIN  
TEST PROCEDURES**

**DIRECT SUPPORT AND GENERAL SUPPORT  
MAINTENANCE LEVELS LOAD TESTING HEAVY  
EXPANDED MOBILITY TACTICAL TRUCK (HEMTT)  
VEHICLE CRANES**

M977 CARGO TRUCK W/O WINCH W/GROVE MODEL M977 CRANE	2320-01-099-6426
M977 CARGO TRUCK W/WINCH W/GROVE MODEL M977 CRANE	2320-01-097-0260
M984 WRECKER W/HIAB MODEL 8109 CRANE	2320-01-097-0248
M984E1 WRECKER W/GROVE MODEL M984 CRANE	2320-01-195-7641
M985 CARGO TRUCK W/O WINCH W/GROVE MODEL M985 CRANE	2320-01-100-7673
M985 CARGO TRUCK W/WINCH W/GROVE MODEL M985 CRANE	2320-01-097-0261
M985E1 CARGO TRUCK W/WINCH W/HIAB MODEL 8108/8108-2 CRANE	2320-01-194-7032
M985E1 CARGO TRUCK W/O WINCH W/HIAB MODEL 8108/8108-2 CRANE	2320-01-194-7031

---

**HEADQUARTERS, DEPARTMENT OF THE ARMY**

Approved for public release; distribution is unlimited.

**23 DECEMBER 1988**

**WARNING**

When loads are applied to the boom cable, all personnel must move away to a safe distance. If the load falls, it could cause serious injury or death to personnel.

Always wear heavy leather gloves when handling wire rope. Never let wire rope run through hands. Frayed wire rope can cut hands.

Grove M984 is used on M984E1 wrecker. The crane used on the M984 wrecker is the HIAB model 8109. Failure to use proper procedure for crane load testing may result in injury to personnel and/or damage to equipment.

Rotate crane either left or right, but never over crane operator. Injury to personnel and/or damage to equipment may occur if crane fails during rotational maneuver.

INSERT LATEST UPDATED PAGES/WORK PACKAGES, DESTROY SUPERSEDED DATE

## LIST OF EFFECTIVE PAGES/WORK PACKAGES

NOTE: The portion of text affected by the updates is indicated by a vertical line in the outer margins of the page. Updates to illustrations are indicated by miniature pointing hands. Updates to wiring diagrams are indicated by shaded areas.

Dates of issue for original and updated pages/work packages are:

Original . . . .0... 23 December 1988  
 Change ... 1 . . . . . 15 February 2002

**TOTAL NUMBER OF PAGES IN THIS PUBLICATION IS 32  
 CONSISTING OF THE FOLLOWING:**

Page/WP No.	*Change No.	Page/WP No.	*Change No.	Page/WP No.	*Change No.
Cover	0	2-1 - 2-16	0	B-1	0
Warning i - ii	0 1	2-17 - 2-20	1	B-2 Blank	0
		A-1 - A-2	0		

\* Zero in this column indicates an original page.

**A/(B Blank)**

CHANGE

NO. 1

HEADQUARTERS  
DEPARTMENT OF THE ARMY  
WASHINGTON, D.C., 15 February 2002

## TECHNICAL BULLETIN

## TEST PROCEDURES

## DIRECT SUPPORT AND GENERAL SUPPORT

MAINTENANCE LEVELS LOAD TESTING HEAVY  
EXPANDED MOBILITY TACTICAL TRUCK (HEMTT)  
VEHICLE CRANES

MODEL	NSN
M977 CARGO TRUCK W/O WINCH W/GROVE MODEL M977 CRANE	2320-01-099-6426
M977 CARGO TRUCK W/WINCH W/GROVE MODEL M977 CRANE	2320-01-097-0260
M984 WRECKER W/HIAB MODEL 8109 CRANE	2320-01-097-0248
M984E1 WRECKER W/GROVE MODEL M984 CRANE	2320-01-195-7641
M985 CARGO TRUCK W/O WINCH W/GROVE MODEL M985 CRANE	2320-01-100-7673
M985 CARGO TRUCK W/WINCH W/GROVE MODEL M985 CRANE	2320-01-097-0261
M985E1 CARGO TRUCK W/WINCH W/HIAB MODEL 8108/8108-2 CRANE	2320-01-194-7032
M985E1 CARGO TRUCK W/O WINCH W/HIAB MODEL 8108/8108-2 CRANE	2320-01-194-7031

Approved for public release; distribution is unlimited.

TB 9-2320-279-34 23 December 1988 is changed as follows:

1. *Remove old pages and insert new pages as indicated below.*
2. *New or changed material is indicated by a vertical bar in the margin of the page.*
3. *Minor changes to illustrations are indicated by a miniature pointing hand.*
4. Illustrations that are new or that have major revisions are indicated by a vertical bar adjacent to the illustration identification number.

**Remove Pages**

None

i-ii

**1-1/(1-2 blank)****2-17 - 2-20****Insert Pages**

A/(B blank)

**i - ii****1-1/(1-2 blank)****2-17 - 2-20**

**File this change sheet in front of the publication for reference purposes.**

By Order of the Secretary of the Army:

ERIC K. SHINSEKI  
*General, United States Army*  
*Chief of Staff*

Official:

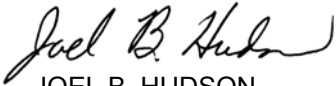
  
JOEL B. HUDSON  
*Administrative Assistant to the*  
*Secretary of the Army*  
0118703

DISTRIBUTION: To be distributed in accordance with the Initial Distribution Number (IDN) 380628, requirements for TB 9-2320-279-34.

## TEST PROCEDURES

### DIRECT SUPPORT AND GENERAL SUPPORT MAINTENANCE LEVELS

### LOAD TESTING HEAVY EXPANDED MOBILITY TACTICAL TRUCK (HEMTT) VEHICLE CRANES

MODEL	NSN
M977 Cargo Truck, w/o Winch, w/Grove Model M977 Crane	2320-01-099-6426
M977 Cargo Truck, w Winch, w/Grove Model M977 Crane	2320-01-097-0260
M984 Wrecker, w/HIAB MODEL 8109 Crane	2320-01-097-0248
M984E1 Wrecker, w/Grove Model M984 Crane	2320-01-195-7641
M985 Cargo Truck, w/o Winch, w/Grove Model M985 Crane	2320-01-100-7673
M985 Cargo Truck, w/Winch, w/Grove Model M985 Crane	2320-01-097-0261
M985E1 Cargo Truck, w/Winch, w/HIAB Model 81 08/81 08-2 Crane	2320-01-194-7032
M985E1 Cargo Truck, w/o Winch, w/HIAB Model 81 08/81 08-2 Crane	2320-01-194-7031

#### REPORTING ERRORS AND RECOMMENDING IMPROVEMENTS

You can help improve this publication. If you find any mistakes or if you know of a way to improve the procedures, please let us know. Submit your DA Form 2028 (Recommended Changes to Equipment Technical Publications), through the Internet, on the Army Electronic Product Support (AEPS) website. The Internet address is <http://aeps.ria.army.mil>. If you need a password, scroll down and click on "ACCESS REQUEST FORM". The DA Form 2028 is located in the ONLINE FORMS PROCESSING section of the AEPS. Fill out the form and click on SUBMIT. Using this form on the AEPS will enable us to respond quicker to your comments and better manage the DA Form 2028 program. You may also mail, fax or E-mail your letter to DA Form 2028 direct to: AMSTA-LC-CI / TECH PUBS, TACOM-RI, 1 Rock Island Arsenal, Rock Island, IL 61299-7360. The email address is TACOM-TECH-PUBS@ria.army.mil. The fax number is DSN 793-0726 or Commercial (309) 782-0726.

Approved for public release; distribution is unlimited.

TABLE OF CONTENTS

	Paragraph	Page
CHAPTER 1	INTRODUCTION	
	Purpose .....	1-1
	Scope .....	1-1
	Requirements for Load Testing .....	1-1
	Requirements for Turntable Bearing Inspection Procedure .....	1-1
CHAPTER 2	PROCEDURES	
	Classification of Tests .....	2-1
	Test Loads .....	2-2
	Fabricating Test Weights .....	2-2
	Load Test Procedures for Grove M977, Grove M984, and Grove M985 Cranes .....	2-4
	Initial Setup .....	2-4
	Test Classification I .....	2-4.2
	Test Classification II .....	2-4.3
	Test Classification IV .....	2-4.4
	Load Test Procedure for HIAB 8109 Crane .....	2-5
	Initial Setup .....	2-5.1
	Test Classification III .....	2-5.2
	Test Classification IV .....	2-5.3
	Load Test Procedures for the HIAB 8108 & 8108-2 Cranes .....	2-6
	Recording Load Rating and Next Periodic Inspection Due Date .....	2-7
	Turntable Bearing Inspection Procedures for Grove M977, Grove M984A1 and Grove M985 Cranes .....	2-8
	Initial Setup .....	2-8.1
	Placement of Dial Indicator .....	2-8.2
	Placement of Telescoping Gage (M977 and M985 only) .....	2-8.3
	Turntable Bearing Inspection Procedures .....	2-8.4
APPENDIX A	REFERENCES .....	A-1
APPENDIX B	PARAGRAPH 5.1.1.1 OF MIL-STD-209F .....	B-1

## CHAPTER 1

### INTRODUCTION

#### 1-1. PURPOSE.

This bulletin supplements instructions contained in TB 43-0142 by establishing specific load test procedures for the vehicle cranes listed in the title.

#### 1-2. SCOPE.

This bulletin tells how to prepare test weights and load test the vehicle cranes listed in the title. These instructions supplement the regular services and inspections described in the HEMTT technical manuals and are to be employed to safety certify applicable HEMTT cranes.

#### 1-3. REQUIREMENTS FOR LOAD TESTING.

Load testing of cranes is required before initial use of all new cranes, cranes that have been extensively repaired, cranes that have undergone modification or alteration, and cranes that have remained idle six or more months. Load testing will be accomplished by support maintenance activities unless manufacturers, repair-contractor or depot, as appropriate, provides written certification that testing has been conducted. Additional load testing may be scheduled, as established locally, based on type of materials handled, equipment utilization and local requirements or conditions.

#### 1-4. REQUIREMENTS FOR TURNTABLE BEARING INSPECTION PROCEDURE.

##### GROUND CONDITIONS AND LEVELING OF THE CRANE.

a. Park the truck on a level surface and use a carpenters level and the crane outrigger system to level the crane from side to side. Rotate the crane as necessary to obtain a surface on the superstructure that can be used to place the level.

##### CLEANING BEFORE INSPECTION.

b. Surfaces where magnetic base mounts and dial indicator plunger or telescope gage indicates off of must be free of grease and dirt, and must be smooth. Clean surfaces as required and if needed, use sand paper to smooth out the surfaces. Surfaces that are not clean or are rough will affect the true dial indicator reading or telescope gage reading.





CHAPTER 2  
PROCEDURES

2-1. CLASSIFICATION OF TESTS.

Table 2-1 lists the tests which are to be employed to safety certify applicable HEMIT cranes. Table 2-2 lists the load ratings which are to be stenciled on the applicable HEMTT crane after completion of all load tests. (Refer to paragraph 2-7). The load rating is the maximum authorized load that maybe lifted by that specific HEMIT crane. Two different types of testing are described in this bulletin:

- a. Static testing, as used in this technical bulletin, is defined as lifting or lowering of the test load without traversing.
- b. Dynamic testing, as described within the bulletin, includes traversing the test load.

Table 2-1. Classification

Crane Model	Test Classification			
	I	II	III	IV
Grove M977	x	x		x
Grove M984 (on M984E1 vehicle)	x	x		x
Grove M985	x	x		x
HIAB 8108 & 8108-2 (on M985E1 vehicle)				x
HIAB 8109 (on M984 vehicle)			x	x

**NOTE**

The difference in the test requirements between Test Classification II (125 percent) and Test Classification III (110 percent) is due to the difference in overload protection systems of the HIAB and Grove Cranes.

Test Classification I is a static overload protection test performed to assure proper setting of overload protection switches on Grove Cranes.

Test Classification II is a static proof test performed to assure the structural integrity of Grove Cranes at 125 percent of the maximum rated load or the maximum load the crane overload protection system will allow the crane to lift,

Test Classification III is a static test used to assure structural integrity of HIAB Cranes at 110 percent of their maximum rated load.

Test Classification IV is a dynamic functions test performed to assure operability of crane and outriggers. All cranes are tested at 100 percent of their maximum rated load. The HIAB 8108 Crane dynamic testing is at 110 percent of the load rating.

**Table 2-2. Load Ratings**

<b>Crane Model</b>	<b>Load Rating (pounds)</b>	<b>Load Radius (Feet' and Inches ")</b>
<b>Grove M977</b>	<b>4,500</b>	<b>9'</b>
<b>Grove M984 (on M984E1)</b>	<b>14,000</b>	<b>9'</b>
<b>Grove M985</b>	<b>5,400</b>	<b>16'6"</b>
<b>HIAB 8108 &amp; 8108-2 on M985E1</b>	<b>4,090</b>	<b>20'6"</b>
<b>HIAB 8109 (on M984)</b>	<b>10,000</b>	<b>12'</b>

**2-2. TEST LOADS.**

Test loads for HEMIT Cranes may take the form of weights that are locally fabricated, or any available item of the proper weight. (The weight of any lifting slings, hooks or rigging should be considered in selecting or instructing test weights). A calibrated load indicator or a calibrated dynamometer may be used for static testing. All load testing devices should have a valid calibration label affixed in a visible place. If a calibrated dynamometer is used, be sure it has a minimum capacity of twice the load test value for proper accuracy.

**2-3. FABRICATING TEST WEIGHTS.**

Table 2-3 lists the test loads that are required for testing the various HEMIT Cranes. Although no unique fabrication details are given, Table 2-4 gives weight details for bulk plate steel of varying thickness. If weights are constructed by welding plates together, allowance should be made for additional weight added by the welding process. All lifting slings hooks, and rigging should comply with the strength requirements given in MIL-STD-209F, paragraph 5.1.1.1. (Refer to Appendix B). Mark value clearly on each weight.

Table 2-3. Required Test Loads

<b>*Test Loads (Lbs.)</b>				
<b>Crane Model</b>	<b>Test Classification</b>			
	<b>I</b>	<b>II</b>	<b>III</b>	<b>IV</b>
<b>Grove M977</b>	<b>3,000, 5,200</b>	<b>3,500</b>		<b>2,500</b>
<b>Grove M984 (on M984E1)</b>	<b>7,300, 9,700, 14,200, 16,500</b>	<b>15,000</b>		<b>12,000</b>
<b>Grove M985</b>	<b>6,200</b>	<b>6,750</b>		<b>5,400</b>
<b>HIAB 8108/8108-2 (On M985E1)</b>				<b>4,500</b>
<b>HIAB 8109 (On M984)</b>			<b>11,000</b>	<b>10,000</b>

- A tolerance of plus or minus 25 lbs. is allowable.

#### **WARNING**

- When loads are applied to the boom cable, all personnel must move away to a safe distance. If the load falls, it could cause serious injury or death to personnel.

Always wear heavy leather gloves when handling wire rope. Never let wire rope run through hands. Frayed wire rope can cut hands.

## 2-4. LOAD TEST PROCEDURES FOR GROVE M977, GROVE M984, AND GROVE M985 CRANES.

Table 2-4. Weight Details for Bulk Plate Steel*					
Size (Thickness by width) (inches)	Weight (Pounds/ linear foot)	Weight (Pounds/ square foot)	US Standard gage	Weight (Pounds/ linear foot)	Weight (Pounds/ square foot)
5/8 x 84	178.7	25.53	0000000	N/A	20.409
5/8 x 96	204.2	25.53	0000000	N/A	19.123
3/4 x 84	214.4	30.63	000000	N/A	17.856
3/4 x 96	245.0	30.63	00000	N/A	16.588
7/8 x 84	250.2	35.74	000	N/A	15.302
7/8 x 96	285.9	35.74	00	N/A	14.035
1 x 84	285.9	40.84	0	N/A	12.748
1 x 96	326.7	40.84*	1	N/A	11.481
1-1/4 x 84	357.3	50.05	2	N/A	10.848
1-1/4 x 96	408.4	51.05	3	N/A	10.4
1-1/2 x 84	428.8	61.26	4	N/A	9.55
1-1/2 x 96	490.1	61.26	5	N/A	8.89
1-3/4 x 84	500.3	71.47	6	N/A	8.28
1-3/4 x 96	571.8	71.47	7	N/A	7.63
2 x 84	571.8	81.68	8	N/A	6.98
2 x 96	653.4	81.68	10	N/A	5.71

● Based on a weight of 40.84 pounds/square foot/inch thickness.

### WARNING

- \* When loads are applied to the boom cable, all personnel must move away to a safe distance. A load that falls can cause serious injury or death to personnel.
- Always wear heavy leather gloves when handling wire rope. Never let wire rope run through hands. Frayed wire rope can cut hands.
- Grove M984 Crane is used on M984E1 Wrecker. The crane used on the M984 Wrecker is the HIAB Model 8109 (see paragraph 2-5). Failure to use proper procedure for crane load testing may result in injury to personnel and/or damage to equipment.

#### 2-4.1 Initial Setup.

- a. Park vehicle on hard, level surface.
- b. Inspect crane in accordance with Appendix A of TB43-0142. Equipment having defects shall be repaired in accordance with the appropriate technical manual.
- c. Setup crane (Refer to TM 9-2320-279-10).

d. Connect the remote control. Exercise all crane functions to their full extent, without a load, for a period of 15 minutes. (Refer to TM 9-2320-279-10).

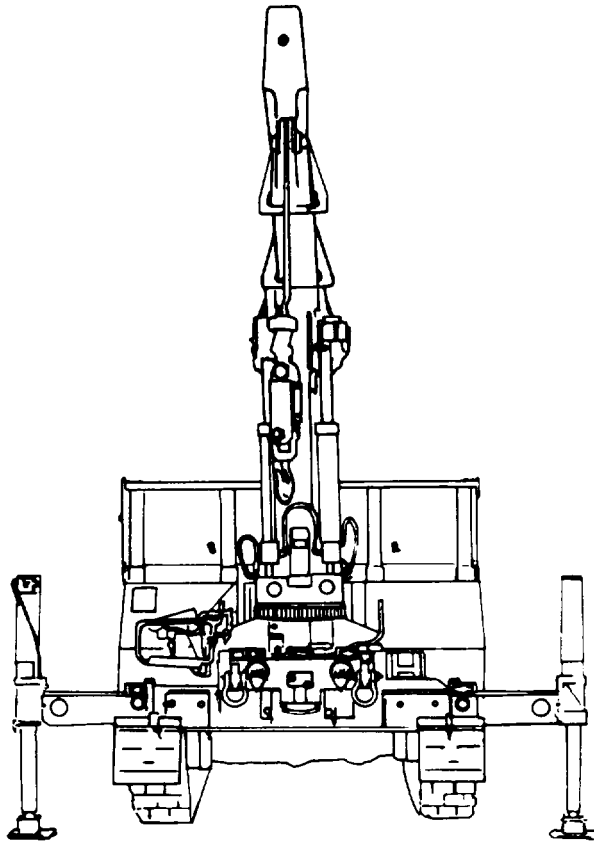

FIGURE 2-1. Boom In Line With Centerline.

e. Position the crane boom in line with centerline of vehicle. (See FIGURE 2-1).

#### 2-4.2. Test Classification I: Static Overload Protection Test.

Check for correct setting of overload protection switches. (Refer to TM 9-2320-279-34).

2-4.3. Test Classification II: Static Proof Test.

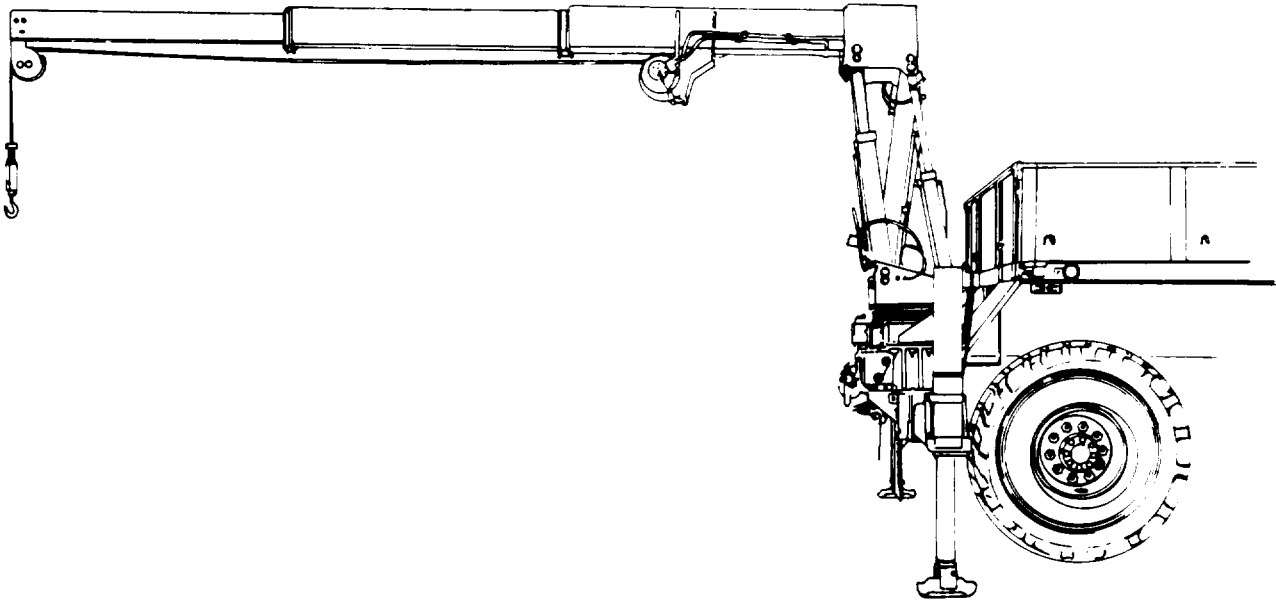

FIGURE 2-2. Boom Parallel to Ground.

- a. Disconnect remote control, use the manual station for this test. (Refer to TM 9-2320-279-10).

**NOTE**

Step b. applies only to the Grove M977 and Grove M985 Cranes.

- b. Position Grove M977 and M985 boom parallel to the ground. Extend boom to length given in Table 2-5 and attach test load.

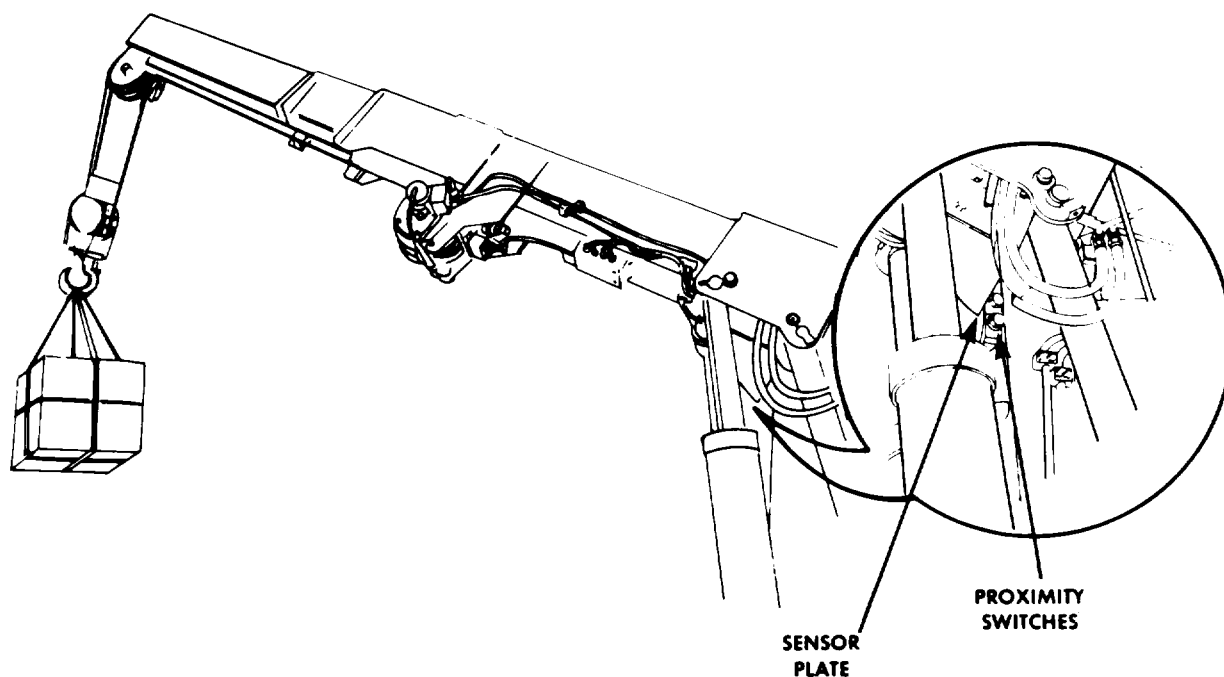

FIGURE 2-3. M984 Crane Sensor Plate.

**NOTE**

Step c. applies only to the Grove M984 Crane.

c. Position Grove M984 boom so that the boom sensor plate completely covers only the top proximity switch (see Figure 2-3). Extend boom to length given in Table 2-5 and attach test load.

Table 2-5. Test Classification I Conditions

Grove Crane Model	*Boom Extension Feet(') and Inches (")	Rated Load Pounds	Test Load Pounds (Percent of Rated Load)
M977	19'	2,500	3,500 (140 Percent)
M984	11'10"	12,000	15,000 (125 Percent)
M985	16'6"	5,400	6,750 (125 Percent)

● Boom extension is measured on a horizontal line from the center of the turntable to the center of the hoist line with load attached.



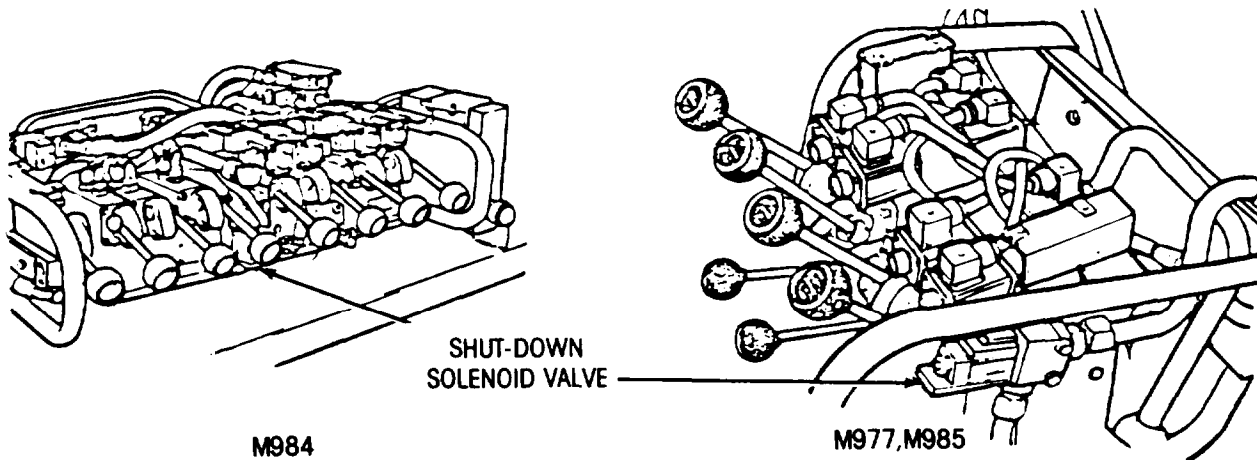

FIGURE 2-4. M977, M984, and M985 Shutdown Solenoid Valve.

**NOTE**

Steps d. and e. are performed to bypass the crane overload system.

d. Place crane power switch in off position.

e. Place a flat tip screwdriver in slot in front of (M977 and M985 Grove Cranes) or below (M984 Grove Crane) shutdown solenoid to hold shutdown valve closed for steps f., g., and h. (See FIGURE 2-4).

**NOTE**

\* Use the manual boom control when performing step g. on the M977 and M985 Grove Cranes. Use the manual hoist control when performing step g. on the Grove M984 Crane.

\* All test loads should be raised slowly and smoothly.

f. Raise the test load approximately six inches off ground.

g. Hold load stationary. Observe performance of crane structure and note any evidence of possible failure.

h. Lower load completely. Remove flat tip screwdriver from solenoid valve.

i. Thoroughly inspect crane in accordance with Appendix A of TB43-0142.

**NOTE**

Crane should not be able to lift load in step j. If crane lifts load, reset crane overload protection switches (Refer to TM 9-2320-279-34).

j. Connect remote control, set crane power switch to ON position. Attempt to lift test load.

## 2-4.4. Test Classification IV: Dynamic Functional Test.

- a. Position boom in line with centerline of vehicle. Extend and raise boom as given in Table 2-6.

Table 2-6. Test Classification IV Conditions

Grove Crane Model	*Boom Extension (Load Radius) Feet (') and Inches (")	**Test Load Pounds	Initial Boom Position (Elevation)
M977	19'	2,500 Lbs.	Parallel to Ground
M984	11'10"	12,000 Lbs.	***
M985	16'6"	5,400 Lbs.	Parallel to Ground

- Boom extension is measured on a horizontal line from the center of the turntable to the center of the hoist line with load attached.
  - \*Test load is 100 percent of load rating.
  - \*\*Raised boom so that sensor plate covers only top proximity switch (see Figure 2-3).
- b. Attach test load to crane hook.
- c. Use crane winch to raise test load to a height of 18 inches (plus or minus three inches).
- d. When test load has stopped swaying, measure and record distance from load to ground.
- e. Disengage Power Take Off (PTO) and shut off vehicle engine. (Refer to TM 9-2320-279-10).
- f. Allow vehicle to sit undisturbed for 30 minutes. Measure distance between load and ground again. Note any difference between measurements. The difference in the two measurements should not be greater than 12 inches. If difference is greater than 12 inches, determine the cause, repair crane, and retest.

**Warning**

Never rotate crane over crane operator. Injury or death to personnel and/or damage to equipment may occur if crane fails during rotational maneuver.

**CAUTION**

Do not contact vehicle with test load. Damage to vehicle may result.

**NOTE**

Two soldiers are required to do step g.; one to operate the crane and one to signal the crane operator to ensure that the load does not hit the side of the vehicle.

g. Rotate crane boom first right and then left, stopping short of load contacting the vehicle. Return crane boom to a position in line with the centerline of vehicle.

**CAUTION**

Do not contact crane with test load. Damage to crane may result.

h. Raise boom to maximum elevation. Raise and lower test load with crane winch. Return boom to initial elevation. Retract and extend boom. Do not exceed rated load radius. All crane movements should be smooth (without jerking). If not, determine the cause, repair, and retest.

i. End of test. Lower and disconnect load. Return crane to stowage position and shut down. (Refer to TM 9-2320 -279-10).

**2-5. LOAD TEST PROCEDURES FOR HIAB 8109 CRANE.**

**2-5.1. Initial Setup.**

a. Park vehicle on a hard level surface.

b. Inspect the crane in accordance with Appendix A of TB43-0142. Equipment having defects should be repaired in accordance with the appropriate technical manual.

c. Setup crane and exercise all crane functions to their full extent, without a load, for a period of 15 minutes. (Refer to TM 9-2320-279-10 or TM 9-2320-354-10).

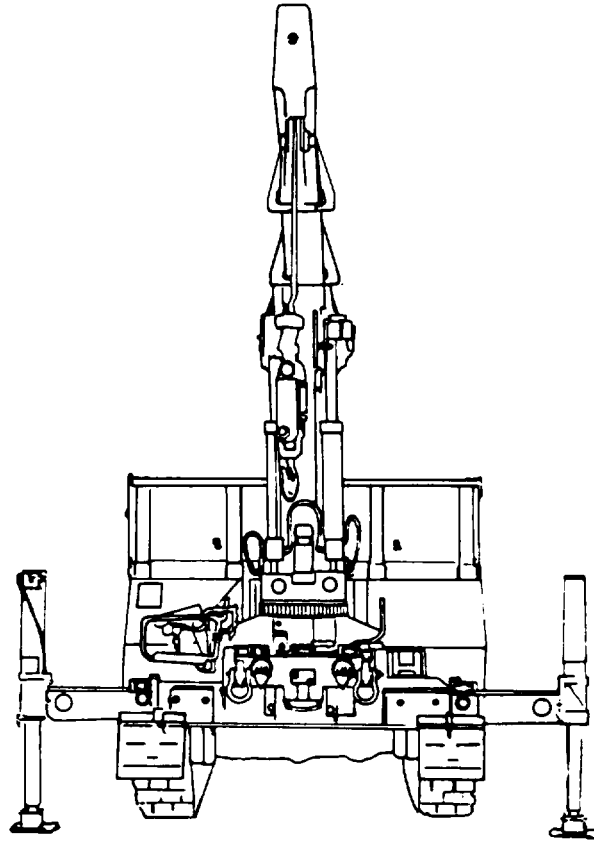

FIGURE 2-5. Boom In Line With Centerline.

- d. Position the crane boom in line with centerline of the vehicle. (See Figure 2-5).

2-5.2. Test Classification III: 110 percent Static Lift Test.

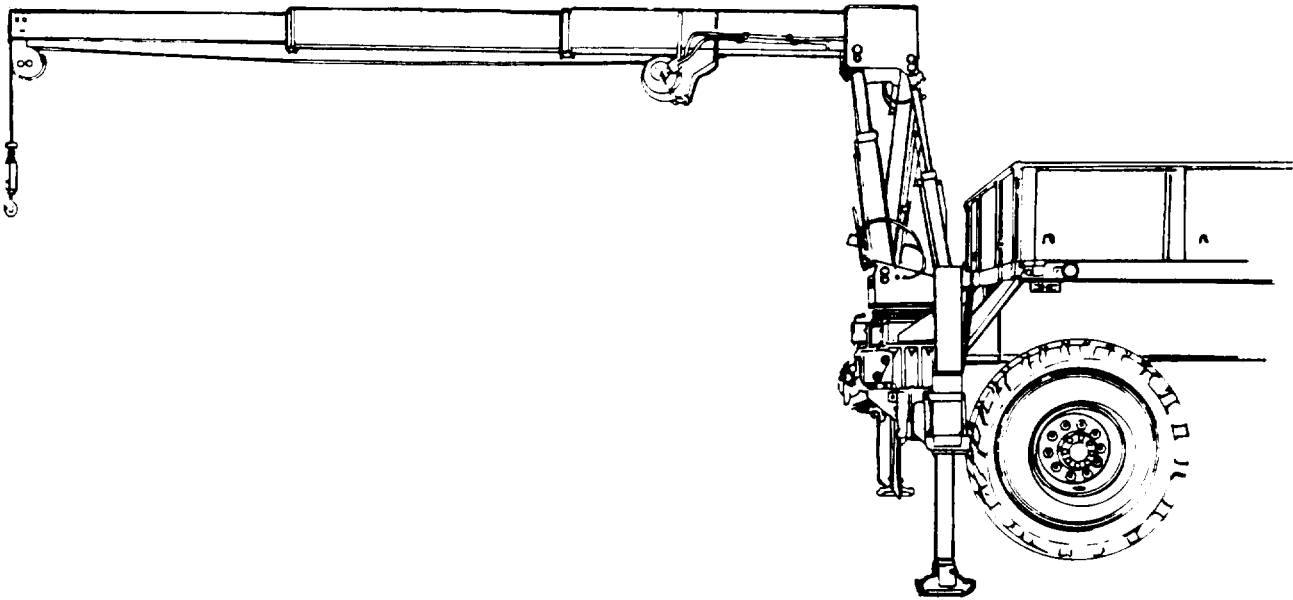

FIGURE 2-6. HIAB 8109 Crane with boom in line with centerline.

a. Position boom parallel to ground. (See Figures 2-5 or 2-6). Extend boom to length given in Table 2-7 and attach test bad.

Table 2-7. Test Classification III Conditions

HIAB Crane Model	*Boom Extension (Load Radius) feet (')	Rated Load Pounds	Test Load Pounds (Percent of Rated Load)
8109	12'	10,000	11,000 (110 Percent)

I Boom extension is measured on a horizontal line from center of turntable to the center of the vertical hoist line with load attached.

**NOTE**

I Use the manual boom control when performing step b. on crane winch control on the HIAB 8109 Crane.

I All test loads should be raised smoothly so as not to create a sudden trounce.

b. Raise the test bad to a height of six inches.

c. Hold load stationary. Observe performance of crane structure and note any evidence of possible failure. Lower load completely.

d. Thoroughly inspect crane in accordance with Appendix Aof TB43-0142.

2-5.3. Test Classification IV: Dynamic Functional Test.

a. Connect remote control. (Refer to TM 9-2320-279-10 or TM 9-2320-354-10).

b. Position boom parallel to ground. (See Figure 2-5 or 2-6). Extend boom to length given in Table 2-8 and attach test bad.

Table 2-8. Test Classification IV Conditions

HIAB Crane Model	*Boom Extension (Load Radius) feet (')	**Test Load Pounds
8109	12'	10,000

● Boom extension is measured on a horizontal line from center of turntable to center of the vertical hoist line with bad attached.

● \*Test load is 100 percent of load rating.

c. Use the crane winch to raise test bad to a height of 18 inches (plus or minus three inches).

d. When load stops swaying, measure and record the distance from the load to the ground.

e. Disengage PTO and shutoff vehicle engine.

f. Allow the vehicle to sit undisturbed for 30 minutes. Again, measure the distance between the load and the ground. Note any differences between the two measurements. The difference between the two measurements should not be greater than 12 inches. If the difference is greater than 12 inches, determine the cause, repair the crane, and retest.

**WARNING**

Rotate crane either left or right, but never over crane operator. Injury or death to personnel and/or damage to equipment may occur if crane fails during rotational maneuver.

**CAUTION**

Do not contact vehicle with test bad. Damage to vehicle may result.

**NOTE**

Two soldiers are required to do step g.; one to operate crane and one to signal crane operator to ensure that bad does not hit side of vehicle.

g. Upon successful completion of steps a. through f, rotate the crane boom left, then right, stopping short of the load contacting the vehicle. Return the crane boom to initial test position. (See Figures 2-5 or 2-6).

h. Raise boom to maximum elevation. Raise and lower test bad with crane winch. Return boom to position parallel to ground. Retract and extend the boom. Do not exceed the rated load radius. (See Table 2-7). All crane movements should be smooth (without jerking). If not, determine the cause, repair, and retest.

i. End of test lower and disconnect bad. Return crane to stowage position and shutdown. (Refer to TM 9-2320-279-10 or TM 9-2320-354-10).

**2-6. LOAD TEST PROCEDURE FOR THE HIAB 8108 & 8108-2 Cranes.**

a. Park vehicle on a hard level surface.

b. Inspect crane in accordance with Appendix A of TB 43-0142. Equipment having defects should be repaired in accordance with the appropriate technical manual.

**NOTE**

Always use main control panel during the HIAB 8108 & 8108-2 Crane Load Test. Use of the remote controls may lead to a false overload indication.

c. Deploy outriggers. Exercise all crane functions without bad, to their full extent, for a period of 15 minutes. (Refer to TM 9-2320-355-10 and TM 9-2320-279-10).

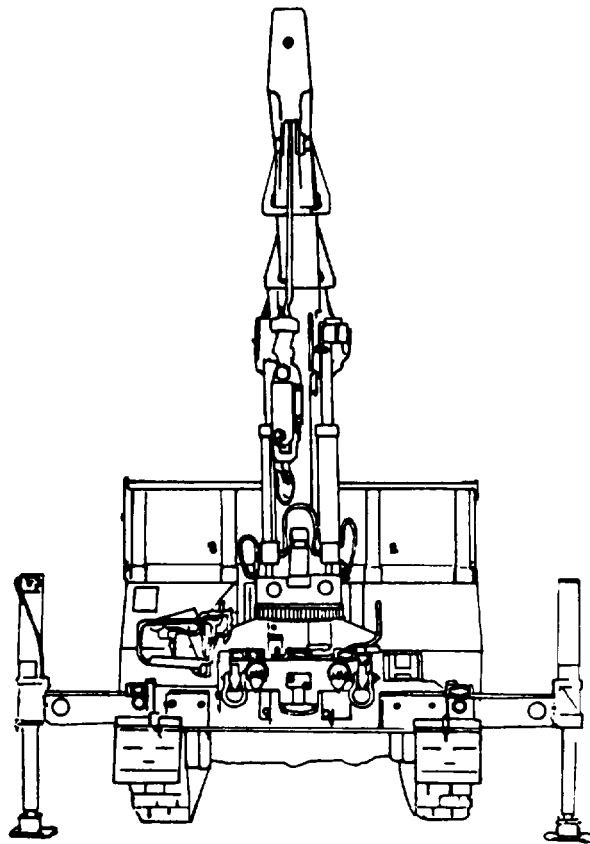

FIGURE 2-7. Boom in Line with Centerline.

d. Position the crane boom in line with the centerline of the vehicle. (See FIGURE 2-7).

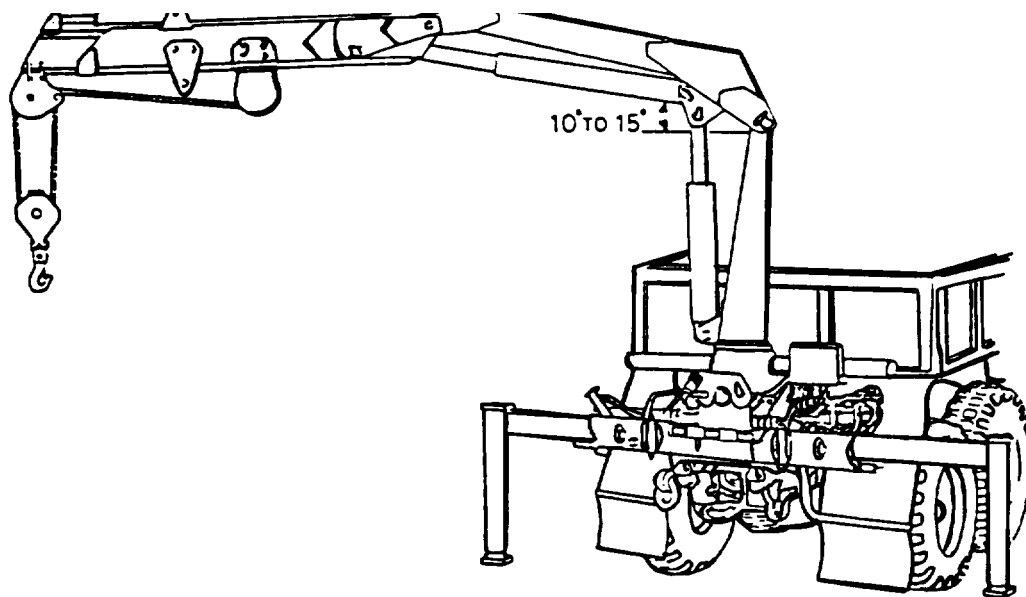

FIGURE 2-8. Boom Positions at Maximum Extension.



**CAUTION**

Do not contact vehicle with test bad. Damage to vehicle may result.

e. Position the inner boom 10 to 15 degrees from horizontal and the outer boom horizontal at the maximum boom extension.

f. Attach a certified load of 4,500 pounds (plus or minus 25 pounds) to the crane hook. Use the crane winch to raise the test load to a height of 18 inches (plus or minus three inches).

g. When test load stops swaying, measure and record the distance from the load to the ground.

h. Disengage the PTO and shut off the vehicle engine. (Refer to TM 9-2320-279-10).

i. Allow the vehicle and crane to set undisturbed for 30 minutes. Again, measure the distance between the load and the ground. Note the difference between the two measurements. The difference in the two measurements should not be greater than 12 inches. If the difference is greater than 12 inches, determine the cause, repair, and retest.

**WARNING**

Rotate crane either left or right but never over crane operator. Injury or death to personnel and/or damage to equipment may occur if crane fails during rotational maneuver.

**CAUTION**

Take care not to contact vehicle with test bad. Damage to vehicle may result.

**NOTE**

Always use main control panel during this crane load test. Use of the remote controls may lead to a false overload indication.

j. Upon successful completion of steps a. through i., rotate the crane boom left and right, stopping short of load contacting the vehicle.

k. Return boom to a position in line with centerline of vehicle. Raise boom to maximum elevation. Raise and lower test bad with crane winch. Return outer boom to a horizontal position. Retract and extend boom. All crane movements should be smooth (without jerking); if not, determine the cause, repair, and retest.

**2-7. RECORDING LOAD RATING AND NEXT PERIODIC INSPECTION DUE DATE.**

After satisfactory completion of load tests, stencil the bad rating including bad radius on the side of the boom or mast using one-half inch letters. Stencil markings will be the same color as other vehicle markings. (Refer to TB 43-0209).

## 2-8. TURNTABLE BEARING INSPECTION PROCEDURES FOR GROVE M977, GROVE M984, AND GROVE M985 CRANES.

### 2-8.1. Initial Setup.

#### NOTE

- Ensure that the turntable bearing is lubricated and that all the turntable mounting bolts have been tightened to the recommended torque.
  - Operate the crane controls smoothly to avoid any jerking or harsh movement that could affect the dial indicator reading.
  - Perform steps a. through c. for GROVE M984 cranes.
  - Perform steps b. and d. for GROVE M977 and M985 cranes.
- a. Lower fairlead into operating position (Refer to TM 9-2320-279-10).
  - b. Place crane in operating position and level side to side with outriggers (Refer to TM 9-2320-279-10).
  - c. Keeping boom level, lower mast until approximately one inch (24.4 mm) clearance is present between the erection cylinder and the crane outrigger cover. Rotate the crane in both directions to ensure no contact will be made with the outrigger cover by either the cylinder or the tension links. Adjust the clearance if contact might occur.
  - d. Keeping boom level, lower mast until approximately one inch (24.4 mm) clearance is present between the erection cylinders and the rear cargo body panel. Rotate the crane in both directions to ensure no contact will be made with the rear cargo body panel by either cylinder. Adjust the clearance if contact might occur.

### 2-8.2. Placement of Dial Indicator.

#### NOTE

- To obtain a true reading of bearing vertical movement, the dial indicator and magnetic base must be positioned correctly.
  - Perform step e. for placement of dial indicator for M977 and M985 trucks.
- a. Ensure that the plunger of the dial indicator is straight up and down in all directions, front to back and side to side. It is not necessary to measure this, but try to get it as close as possible with a visual inspection from different angles.
  - b. Ensure that the dial indicator is pre-loaded at least one turn by allowing the needle to complete one turn around the dial before zeroing the dial.
  - c. Ensure that the magnetic base is secure at its attachment point so it will not move and contribute to a false indicator reading.
  - d. The dial indicator must be in line with the axial centerline of the boom for all measurements.
  - e. Due to the position of the crane power/remote control junction box, it is not possible to position the boom at exact 90 degree and 180 degree positions and have a mounting spot for the magnetic base. Position the magnetic base first and then rotate the boom to place the boom axial centerline over the magnetic base, then install the dial indicator.
  - f. To ensure a consistent reading, the dial indicator plunger must be as close as possible to the outside diameter of the swing gear tooth tip, as the allowable bearing movement only applies at the tip of the gear tooth. The indicator reading will be magnified if the plunger contact point is off of the outer diameter of the swing gear tooth tip.
  - g. Always verify that the dial indicator reading is correct by lowering the boom from the 60 degree boom angle to the level boom angle, then check that the dial indicator returns to the zero position. Repeat the procedure if the dial indicator does not return to the zero position.

2-8.3. Placement of Telescoping Gage (M977 and M985 only).

**NOTE**

To obtain a true reading of bearing vertical movement, the telescoping gage must be positioned correctly.

- a. Ensure that the gage is straight up and down in all directions, front to back and side to side. It is not necessary to measure this, but try to get it as close as possible with a visual inspection from different angles.
- b. The telescoping gage must be in line with the axial centerline of the boom for all measurements.
- c. To ensure a consistent reading, the telescoping gage must be as close as possible to the outside diameter of the swing gear tooth tip, as the allowable bearing movement only applies at the tip of the gear tooth. The gage reading will be magnified if the contact point is off of the outer diameter of the swing gear tooth tip.
- d. Always verify that the reading is correct by measuring at least twice.

2-8.4. Turntable Bearing Inspection Procedures.

**WARNING**

When performing these inspection procedures, do not position yourself underneath the boom when the crane controls are being operated. Failure to comply could result in severe injury or death to personnel.

Tools Required

1. Dial indicator with at least one inch of plunger travel with .001 inch graduations.  
NSN 5210-00-794-9178
2. Magnetic base for dial indicator.  
NSN 5210-01-334-9865 or 5210-01-368-5829
3. Carpenters level.  
NSN 5210-00-239-0892
4. Telescoping gage (M977 and M985 only).  
NSN 5210-00-221-2087
5. Micrometer (M977 and M985 only).  
NSN 5210-00-554-7134
6. Magnetic protractor.  
NSN 5210-01-415-0075

**NOTE**

- Any reading equal to or over .065 inch (1.65 mm) will require a new bearing to be ordered and installed as soon as possible. If that reading occurs on the first step of the inspection, it is not necessary to continue the inspection. However, even if the first reading is within the specifications, it is still necessary to complete all of the remaining steps in the inspection procedure.
- For measurements with the boom nose positioned over rear and front of M977, M984A1, and M985, perform steps b. through g.
- For measurements with the boom nose positioned over driver and passenger side of M984A1, perform steps b. through g.
- For measurements with the boom nose positioned over driver and passenger side of M977 and M985, perform steps i. through n.

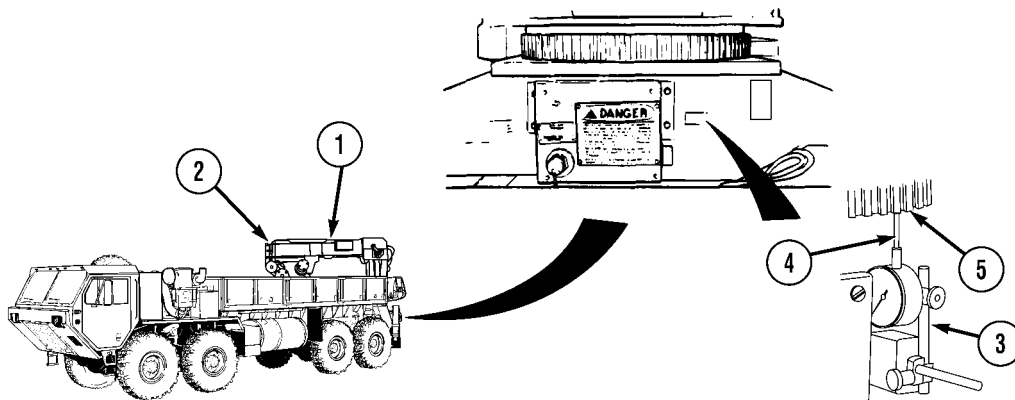

- a. With boom angle level, rotate boom (1) and position boom nose (2) to the front of the truck (Refer to TM 9-2320-279-10).
- b. Install a dial indicator (3) with magnetic base. Plunger (4) of dial indicator (3) must be in line with the axial centerline of the crane boom (1), with the plunger tip centered as close as possible under or over the tip of the swing gear tooth (5).

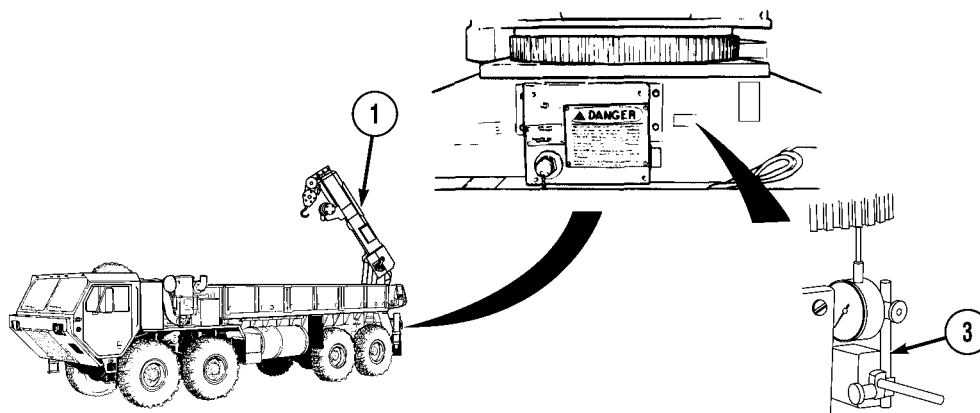

- c. Adjust dial indicator (3) to preload the dial, then zero the dial indicator (3).
- d. Operate boom up control until boom angle is 60 degrees.
- e. Record dial indicator (3) reading.
- f. If reading is equal to or over .065 inches (1.65 mm), institute bearing replacement procedures. If reading is under .065 inches (1.65 mm), continue the inspection procedure.
- g. If all readings are under .065 inches (1.65 mm), the inspection procedure is complete, return crane to service.
- h. Level boom angle and rotate boom to the passenger side of the truck. Repeat steps b. through g. for measurements with boom positioned to both passenger and driver side.

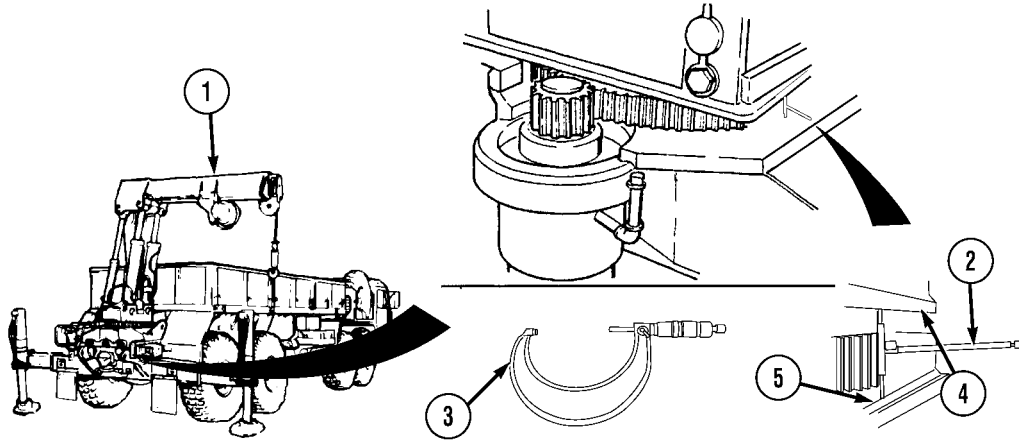

**NOTE**

Measurements with boom nose positioned over passenger side shown.

- i. Lower boom (1) to obtain a level boom angle.
- j. Use the telescoping gage (2) and micrometer (3) to measure the distance between the bottom of the superstructure (4) and the subframe (5). The telescoping gage (2) must be in line with the axial centerline of the crane boom, with the gages barrel just touching the swing gear tooth. Record measurement.
- k. Operate boom up control until boom angle is 60 degrees.

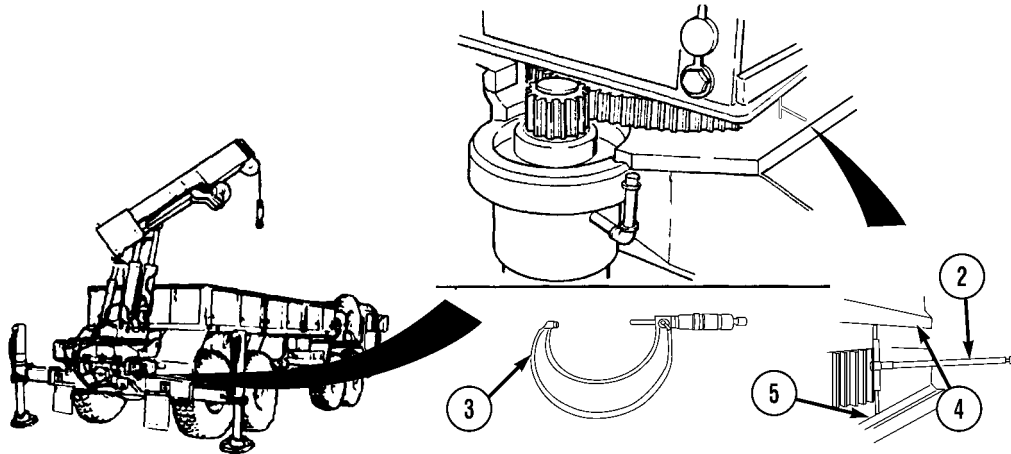

- l. Use the telescoping gage (2) and micrometer (3) to measure the distance between the bottom of the superstructure (4) and the subframe (5). The telescoping gage (2) must be in line with the axial centerline of the crane boom, with the gages barrel just touching the swing gear tooth. Record measurement.
- m. If the difference between the two readings is equal to or over .065 inches (1.65 mm), institute bearing replacement procedures. If the difference between the two readings is under .065 inches (1.65 mm), continue the inspection procedure.
- n. If the differences in readings for both passenger and driver side are under .065 inches (1.65 mm), the inspection procedure is complete, return crane to service.

**APPENDIX A****REFERENCES****A-1. SCOPE.**

This appendix lists all forms, field manuals, technical manuals and other publications that are referenced in this bulletin.

**A-2. FIELD MANUALS.**

The following indexes should be consulted frequently for the latest change or revision and for new publications relating to material covered in this technical bulletin.

First Aid for Soldiers . . . . . FM 21-11

**A-3. TECHNICAL MANUALS.**

Operator's Manual, M977 Series, 8x8 Heavy Expanded Mobility Tactical Trucks (HEMTT) . . . . . TM9-2320-279-10

Operator's Manual for Controls and Equipment Found Only on the M985EI Cargo Truck . . . . . TM9-2320-355-10

Operator's Manual for Controls and Equipment Found Only on the M984 Wrecker-Recovery Truck . . . . . TM9-2320-354-10

Organizational Maintenance Manual, M977 Series, 8x8 Heavy Expanded Mobility Tactical Trucks (HEMTT) . . . . . TM9-2320-279-20

Direct Support and General Support Maintenance Manual, M977 Series, 8x8 Heavy Expanded Mobility Tactical Trucks (HEMTT) . . . . . TM 9-2320-279-34

Organizational, Direct Support, and General Support Maintenance Manual (including Repair Parts and Special Tools List) HIAB Model 8108 Crane . . . . . TM 9-2320-355-24&P

Organizational, Direct Support, and General Support Maintenance Manual (including Repair Parts and Special Tools List) for M984 Wrecker-Recovery Truck . . . . . TM9-2320-354-24&P

Repairs and Utilities: Concrete and Masonry . . . . . TM 5-615

Consolidated Index of Army Publications and Blank Forms . . . . . DA PAM 25-30

Index of Graphic Training Aids and Devices . . . . . DA PAM310-5

Safety Inspection and Testing of Lifting Devices . . . . . TB 43-0142

Warranty Technical Bulletin for M977 Series Vehicles . . . . . TB 9-2300-295-15/19

**APPENDIX A (CON'T)**

Color, Marking, and Camouflage Painting of Military Vehicles, Construction  
Equipment, and Materials Handling Equipment . . . . . TB 43-0209

A-4. MISCELLANEOUS PUBLICATIONS

LUBRICATION ORDER for M977 Series, 8x8 Heavy Expanded Mobility Tactical  
Truck . . . . . LO 9-2320-279-12

**APPENDIX B****PARAGRAPH 5.1.1.1. of MIL-STD-209F**

5.1.1.1. For equipment weighing less than 20,000 pounds. Each slinging provision, including the connection and the structural members, shall withstand without permanent deformation, a working load equal to its proportionate share of the MSW (maximum shipping weight) multiplied by 3.2 and shall have an ultimate strength not less than 1.5 times the working load. The proportionate share of the MSW is determined by a static test load or by analysis. A static test load is performed by selecting sling lengths so that the sling apex is over the center of gravity of the equipment and the true angle of each sling leg does not exceed 45 degrees from the vertical. Included in each sling length is a load cell to measure the static load in each leg when the equipment is lifted and held in a static position. For validation, the slinging eyes or provisions shall be tested and shall withstand the required working load for not less than 90 seconds. For external helicopter, transport the requirements for slinging provisions, as stated above, apply to equipment with a MSW to maximum projected frontal area of 60 pounds per square foot or greater. Equipment with a MSW to maximum projected frontal area ratio of less than 60 pounds per square foot shall meet the following requirements:

- a. Each slinging provision, including its connecting structural members, shall withstand without permanent deformation, a working load equal to its proportionate share of the MSW, multiplied by 5.6.
- b. Each slinging provision shall have an ultimate strength not less than 1.5 times the working load.
- c. For validation, the slinging provisions shall be tested and shall withstand the required working load for not less than 90 seconds. MSW for the purpose of this TB, is the value of the test weight.





By Order of the Secretary of the Army

Official:

CARL E. VUONO  
*General, United States Army*  
*Chief of Staff*

WILLIAM J. MEEHAN II  
*Brigadier General, United States Army*  
*The Adjutant General*

Distribution:

To be distributed LAW DA Form 12-38-R, (Block No. 268) Direct Support and General Support Maintenance Requirements for Truck, Cargo, 10-Ton, 8X8, Heavy Expanded Mobility Tactical Truck, HEMIT, M977, M978, M983, M984, M985 (TM 9-2320-279 Series).

RECOMMENDED CHANGES TO EQUIPMENT TECHNICAL PUBLICATIONS



SOMETHING WRONG WITH THIS PUBLICATION?

THEN... JOT DOWN THE DOPE ABOUT IT ON THIS FORM. CAREFULLY TEAR IT OUT. FOLD IT AND DROP IT IN THE MAIL!

FROM: (PRINT YOUR UNIT'S COMPLETE ADDRESS)

US Army Radar - 6  
443rd Battalion (Attn: Sgt Dan)  
Fort Cold, Alaska 10012

DATE SENT

23 January 1986

PUBLICATION NUMBER

TB9-2320-279-34

PUBLICATION DATE

23 DEC 1988

Load Test Procedures for  
HEMTT Cranes

BE EXACT... PIN-POINT WHERE IT IS

PAGE  
NO

PARA-  
GRAPH

FIGURE  
NO

TABLE  
NO

1-1

1-1

IN THIS SPACE TELL WHAT IS WRONG  
AND WHAT SHOULD BE DONE ABOUT IT:

Reference to technical bulletin  
is wrong; should be TB43-0142  
not TB43-0143.

SAMPLE

PRINTED NAME, GRADE OR TITLE, AND TELEPHONE NUMBER

SSG JOHN DOE AU 798-8686

SIGN HERE

John Doe

FILL IN YOUR  
UNIT'S ADDRESS



DEPARTMENT OF THE ARMY  
*US Army Reaction - 6*  
*443rd Battalion (ATTN: SSGDRE)*  
*Fort Cold, Alaska 10012*

OFFICIAL BUSINESS

**SAMPLE**

NO BACK

TEAR ALONG PERFORATED LINE

Commander  
US Army Tank-Automotive Command  
ATTN: AMSTA-MB  
Warren, Michigan 48397-5000

RECOMMENDED CHANGES TO EQUIPMENT TECHNICAL PUBLICATIONS

**SOMETHING WRONG WITH THIS PUBLICATION?**



THEN... JOT DOWN THE DOPE ABOUT IT ON THIS FORM. CAREFULLY TEAR IT OUT. FOLD IT AND DROP IT IN THE MAIL!

FROM: (PRINT YOUR UNIT'S COMPLETE ADDRESS)

DATE SENT

PUBLICATION NUMBER

TB9-2320-279-34

PUBLICATION DATE

23 DEC 1988

Load Test Procedures for  
HEMTT Cranes

BE EXACT ... PIN-POINT WHERE IT IS

PAGE  
NO

PARA-  
GRAPH

FIGURE  
NO

TABLE  
NO

IN THIS SPACE TELL WHAT IS WRONG  
AND WHAT SHOULD BE DONE ABOUT IT:

PRINTED NAME, GRADE OR TITLE, AND TELEPHONE NUMBER

SIGN HERE

FILL IN YOUR  
UNIT'S ADDRESS

FOLD BACK

DEPARTMENT OF THE ARMY

OFFICIAL BUSINESS

Commander  
US Army Tank-Automotive Command  
ATTN; AMSTA-MB  
Warren, Michigan 48397-5000

TEAR ALONG PERFORATED LINE

RECOMMENDED CHANGES TO EQUIPMENT TECHNICAL PUBLICATIONS



THEN... JOT DOWN THE DOPE ABOUT IT ON THIS FORM. CAREFULLY TEAR IT OUT. FOLD IT AND DROP IT IN THE MAIL!

**SOMETHING WRONG WITH THIS PUBLICATION?**

FROM: (PRINT YOUR UNIT'S COMPLETE ADDRESS)

DATE SENT

PUBLICATION NUMBER  
TB9-2320-279-34

PUBLICATION DATE  
23 DEC 1988

Load Test Procedures for  
HEMTT Cranes

BE EXACT... PIN-POINT WHERE IT IS

PAGE NO	PARA-GRAPH	FIGURE NO	TABLE NO
---------	------------	-----------	----------

IN THIS SPACE TELL WHAT IS WRONG AND WHAT SHOULD BE DONE ABOUT IT:

PRINTED NAME, GRADE OR TITLE, AND TELEPHONE NUMBER SIGN HERE

FILL IN YOUR  
UNIT'S ADDRESS



FOLD BACK

DEPARTMENT OF THE ARMY



OFFICIAL BUSINESS

Commander  
US Army Tank-Automotive Command  
ATTN; AMSTA-MB  
Warren, Michigan 48397-5000

TEAR ALONG PERFORATED LINE



RECOMMENDED CHANGES TO EQUIPMENT TECHNICAL PUBLICATIONS



THEN... JOT DOWN THE DOPE ABOUT IT ON THIS FORM. CAREFULLY TEAR IT OUT. FOLD IT AND DROP IT IN THE MAIL!

**SOMETHING WRONG WITH THIS PUBLICATION?**

FROM: (PRINT YOUR UNIT'S COMPLETE ADDRESS)

DATE SENT

PUBLICATION NUMBER  
TB9-2320-279-34

PUBLICATION DATE  
23 DEC 1988

Load Test Procedures for  
HEMTT Cranes

BE EXACT... PIN-POINT WHERE IT IS

PAGE NO	PARA-GRAPH	FIGURE NO	TABLE NO

IN THIS SPACE TELL WHAT IS WRONG AND WHAT SHOULD BE DONE ABOUT IT:

PRINTED NAME, GRADE OR TITLE, AND TELEPHONE NUMBER

SIGN HERE

FILL IN YOUR  
UNIT'S ADDRESS

FOLD BACK

DEPARTMENT OF THE ARMY

OFFICIAL BUSINESS

Commander  
US Army Tank-Automotive Command  
ATTN; AMSTA-MB  
Warren, Michigan 48397-5000

TEAR ALONG PERFORATED LINE

RECOMMENDED CHANGES TO EQUIPMENT TECHNICAL PUBLICATIONS

SOMETHING WRONG WITH THIS PUBLICATION?



THEN... JOT DOWN THE DOPE ABOUT IT ON THIS FORM. CAREFULLY TEAR IT OUT. FOLD IT AND DROP IT IN THE MAIL!

FROM: (PRINT YOUR UNIT'S COMPLETE ADDRESS)

DATE SENT

PUBLICATION NUMBER

TB9-2320-279-34

PUBLICATION DATE

23 DEC 1988

Load Test Procedures for  
HEMTT Cranes

BE EXACT... PIN-POINT WHERE IT IS

PAGE  
NO

PARA-  
GRAPH

FIGURE  
NO

TABLE  
NO

IN THIS SPACE TELL WHAT IS WRONG  
AND WHAT SHOULD BE DONE ABOUT IT:

PRINTED NAME, GRADE OR TITLE, AND TELEPHONE NUMBER

SIGN HERE

FILL IN YOUR  
UNIT'S ADDRESS

FOLD BACK

TEAR ALONG PERFORATED LINE

DEPARTMENT OF THE ARMY

OFFICIAL BUSINESS

Commander  
US Army Tank-Automotive Command  
ATTN; AMSTA-MB  
Warren, Michigan 48397-5000



THEN... JOT DOWN THE DOPE ABOUT IT ON THIS FORM. CAREFULLY TEAR IT OUT. FOLD IT AND DROP IT IN THE MAIL!

# SOMETHING WRONG WITH THIS PUBLICATION?

FROM: (PRINT YOUR UNIT'S COMPLETE ADDRESS)

DATE SENT

PUBLICATION NUMBER  
TB9-2320-279-34

PUBLICATION DATE  
23 DEC 1988

Load Test Procedures for  
HEMTT Cranes

BE EXACT ... PIN-POINT WHERE IT IS

PAGE NO	PARA-GRAPH	FIGURE NO	TABLE NO

IN THIS SPACE TELL WHAT IS WRONG AND WHAT SHOULD BE DONE ABOUT IT:

PRINTED NAME, GRADE OR TITLE, AND TELEPHONE NUMBER

SIGN HERE

FILL IN YOUR  
UNIT'S ADDRESS

FOLD BACK

TEAR ALONG PERFORATED LINE

DEPARTMENT OF THE ARMY

OFFICIAL BUSINESS

Commander  
US Army Tank-Automotive Command  
ATTN; AMSTA-MB  
Warren, Michigan 48397-5000

## THE METRIC SYSTEM AND EQUIVALENTS

### LINEAR MEASURE

1 Centimeter = 10 Millimeters = 0.01 Meters = 0.3937 Inches  
 1 Meter = 100 Centimeters = 1000 Millimeters = 39.37 Inches  
 1 Kilometer = 1000 Meters = 0.621 Miles

### WEIGHTS

1 Gram = 0.001 Kilograms = 1000 Milligrams = 0.035 Ounces  
 1 Kilogram = 1000 Grams = 2.2 Lb  
 1 Metric Ton = 1000 Kilograms = 1 Megagram = 1.1 Short Tons

### LIQUID MEASURE

1 Milliliter = 0.001 Liters = 0.0338 Fluid Ounces  
 1 Liter = 1000 Milliliters = 33.82 Fluid Ounces

### SQUARE MEASURE

1 Sq Centimeter = 100 Sq Millimeters = 0.155 Sq Inches  
 1 Sq Meter = 10,000 Sq Centimeters = 10.76 Sq Feet  
 1 Sq Kilometer = 1,000,000 Sq Meters = 0.386 Sq Miles

### CUBIC MEASURE

1 Cu Centimeter = 1000 Cu Millimeters = 0.06 Cu Inches  
 1 Cu Meter = 1,000,000 Cu Centimeters = 35.31 Cu Feet

### TEMPERATURE

$\frac{5}{9} (^{\circ}\text{F} - 32) = ^{\circ}\text{C}$   
 212<sup>o</sup> Fahrenheit is equivalent to 100<sup>o</sup> Celsius  
 90<sup>o</sup> Fahrenheit is equivalent to 32.2<sup>o</sup> Celsius  
 32<sup>o</sup> Fahrenheit is equivalent to 0<sup>o</sup> Celsius  
 $\frac{9}{5} \text{C}^{\circ} + 32 = \text{F}^{\circ}$

### APPROXIMATE CONVERSION FACTORS

<u>TO CHANGE</u>	<u>TO</u>	<u>MULTIPLY BY</u>
Inches . . . . .	Centimeters . . . . .	2.540
Feet . . . . .	Meters . . . . .	0.305
Yards . . . . .	Meters . . . . .	0.914
Miles . . . . .	Kilometers . . . . .	1.609
Square Inches . . . . .	Square Centimeters . . . . .	6.451
Square Feet . . . . .	Square Meters . . . . .	0.093
Square Yards . . . . .	Square Meters . . . . .	0.836
Square Miles . . . . .	Square Kilometers . . . . .	2.590
Acres . . . . .	Square Hectometers . . . . .	0.405
Cubic Feet . . . . .	Cubic Meters . . . . .	0.028
Cubic Yards . . . . .	Cubic Meters . . . . .	0.765
Fluid Ounces . . . . .	Milliliters . . . . .	29.573
Pints . . . . .	Liters . . . . .	0.473
Quarts . . . . .	Liters . . . . .	0.946
Gallons . . . . .	Liters . . . . .	3.785
Ounces . . . . .	Grams . . . . .	28.349
Pounds . . . . .	Kilograms . . . . .	0.454
Short Tons . . . . .	Metric Tons . . . . .	0.907
Pound-Feet . . . . .	Newton-Meters . . . . .	1.356
Pounds per Square Inch . . . . .	Kilopascals . . . . .	6.895
Miles per Gallon . . . . .	Kilometers per Liter . . . . .	0.425
Miles per Hour . . . . .	Kilometers per Hour . . . . .	1.609

<u>TO CHANGE</u>	<u>TO</u>	<u>MULTIPLY BY</u>
Centimeters . . . . .	Inches . . . . .	0.394
Meters . . . . .	Feet . . . . .	3.280
Meters . . . . .	Yards . . . . .	1.094
Kilometers . . . . .	Miles . . . . .	0.621
Square Centimeters . . . . .	Square Inches . . . . .	0.155
Square Meters . . . . .	Square Feet . . . . .	10.764
Square Meters . . . . .	Square Yards . . . . .	1.196
Square Kilometers . . . . .	Square Miles . . . . .	0.386
Square Hectometers . . . . .	Acres . . . . .	2.471
Cubic Meters . . . . .	Cubic Feet . . . . .	35.315
Cubic Meters . . . . .	Cubic Yards . . . . .	1.308
Milliliters . . . . .	Fluid Ounces . . . . .	0.034
Liters . . . . .	Pints . . . . .	2.113
Liters . . . . .	Quarts . . . . .	1.057
Liters . . . . .	Gallons . . . . .	0.264
Grams . . . . .	Ounces . . . . .	0.035
Kilograms . . . . .	Pounds . . . . .	2.205
Metric Tons . . . . .	Short Tons . . . . .	1.102
Newton-Meters . . . . .	Pound-Feet . . . . .	0.738
Kilopascals . . . . .	Pounds per Square Inch . . . . .	0.145
Kilometers per Liter . . . . .	Miles per Gallon . . . . .	2.354
Kilometers per Hour . . . . .	Miles per Hour . . . . .	0.621

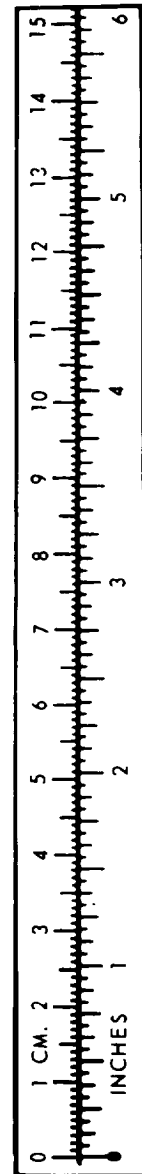

TA089991

**PIN: 065187-001**